

**HYBRID (TRA / TREMLAR OR THERMASTIC)**

TRA-501 Canted Eave Flashing Detail

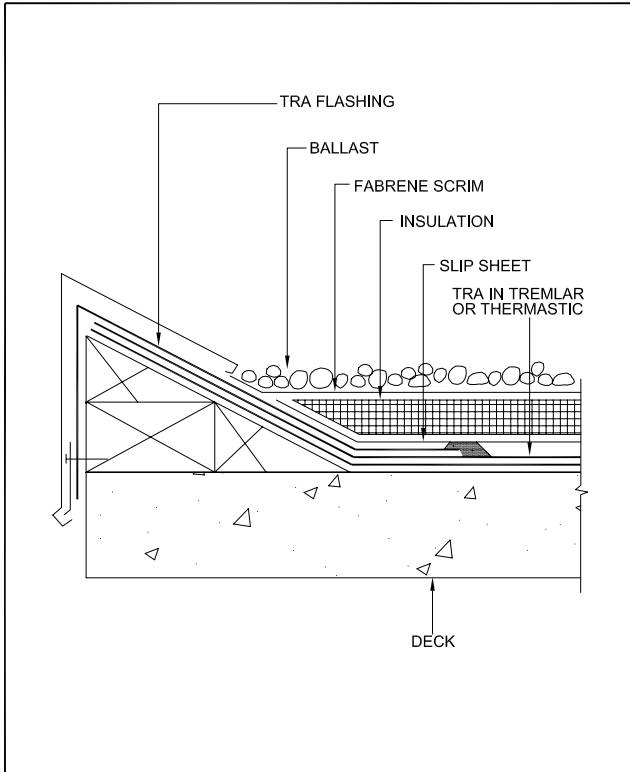

TRA-502 Curb Flashing Detail

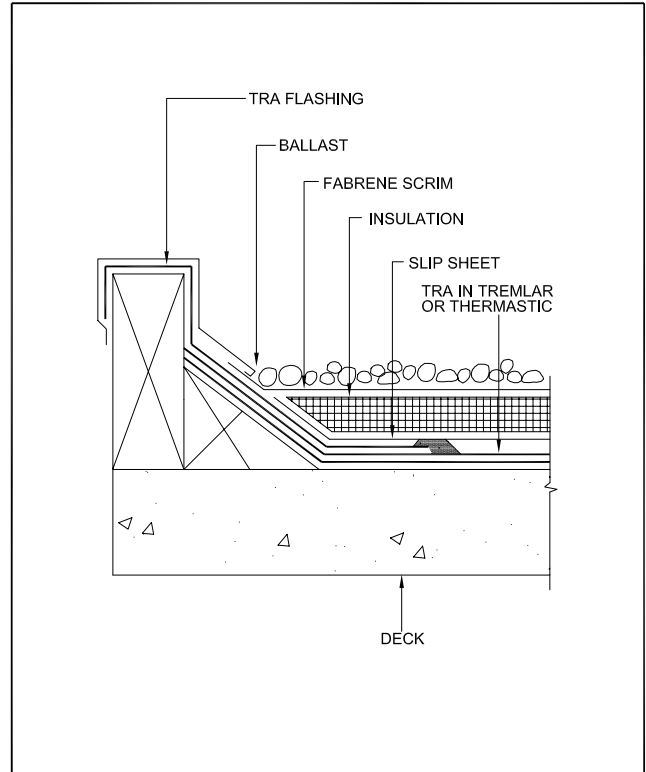

TRA-503 Wall Reglet Joint Flashing Detail

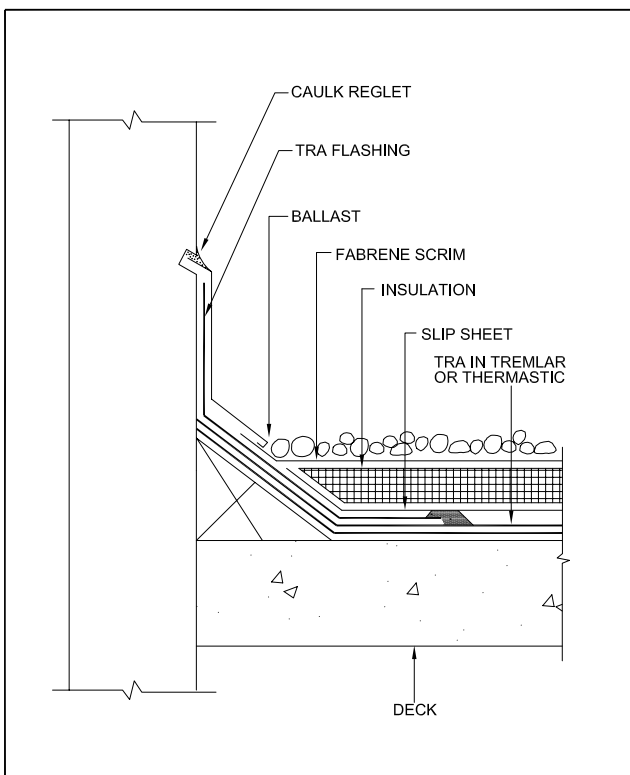

TRA-504 Parapet Wall Flashing Detail

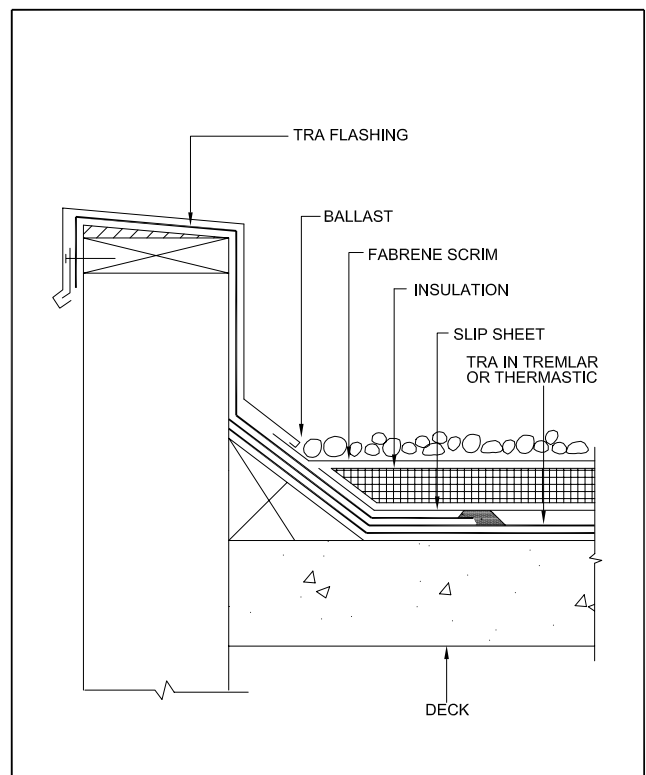

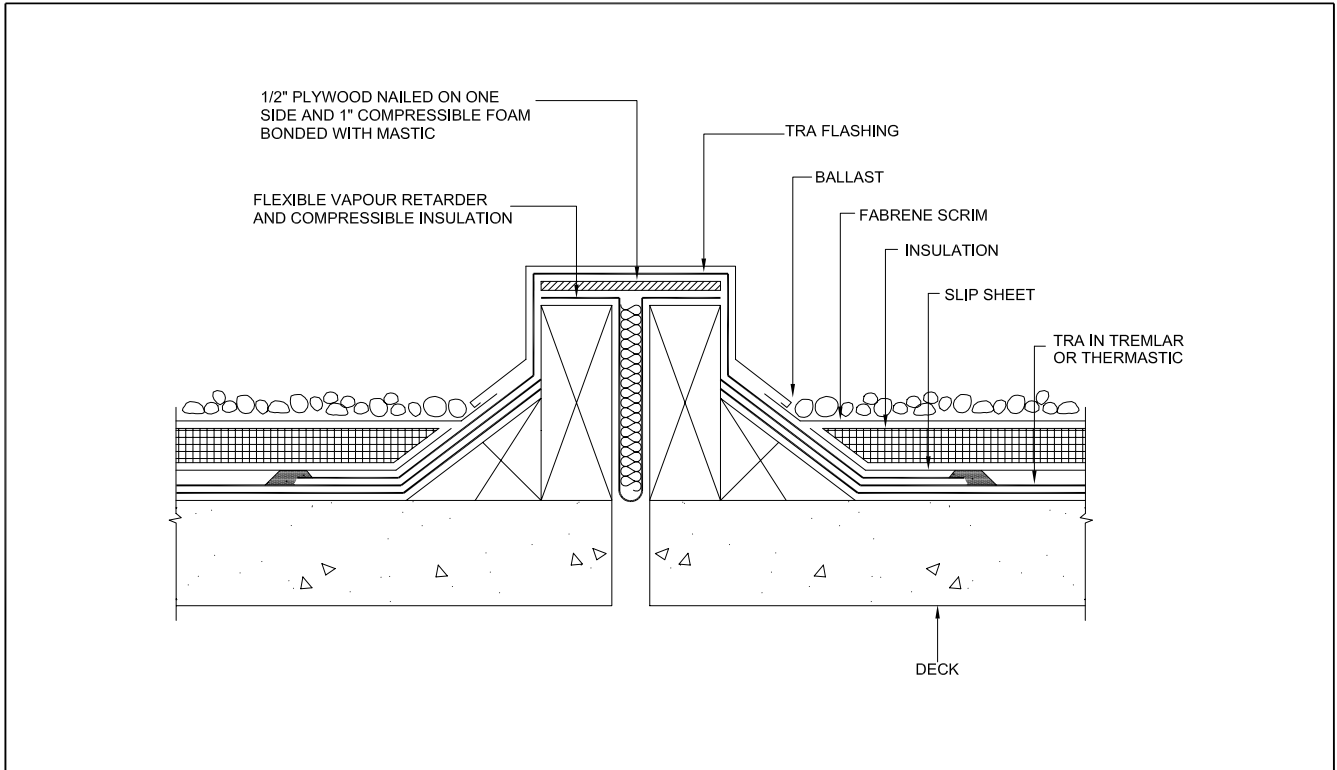
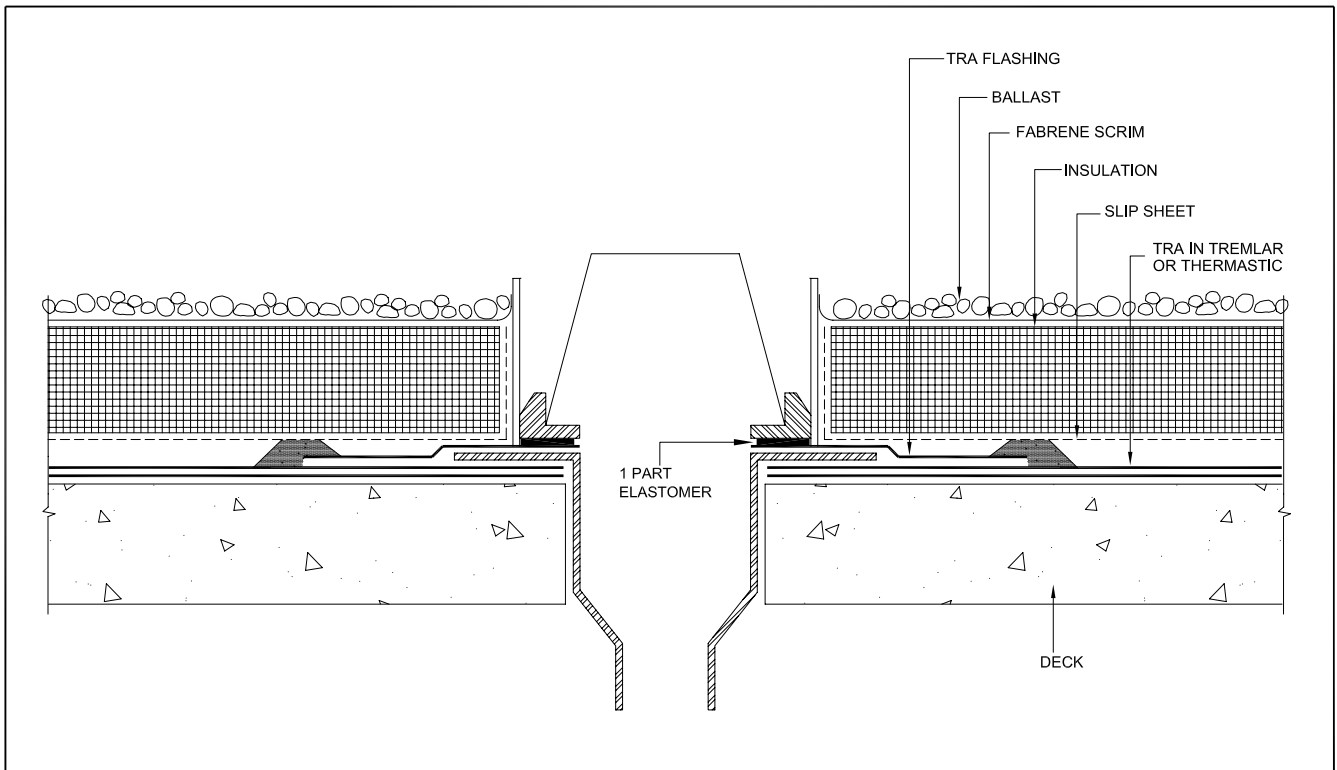
**HYBRID (TRA / TREMLAR OR THERMASTIC)****TRA-505** Expansion Joint Flashing Detail**TRA-506** Drain Flashing Detail

**HYBRID (TRA / TREMLAR OR THERMASTIC)**

TRA-507 Projection Flashing Detail

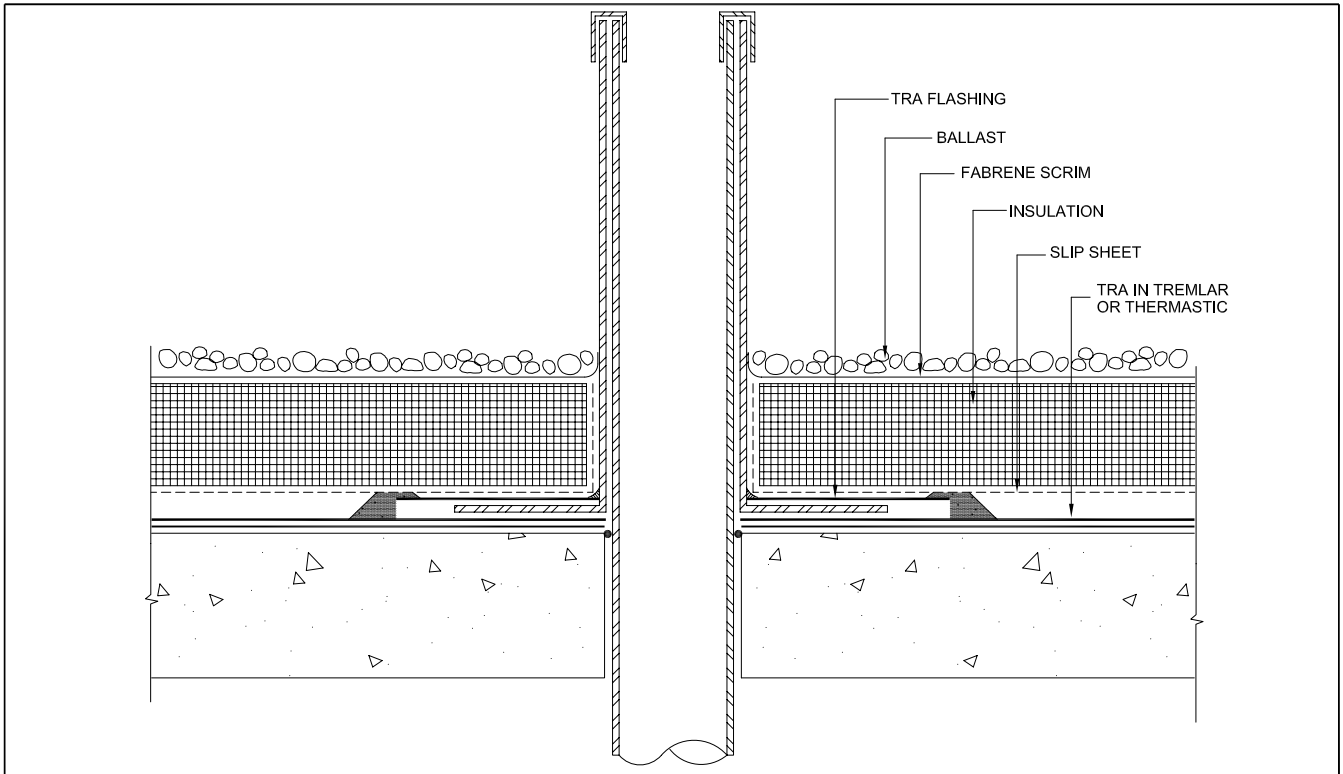

TRA-508 Sleeper Flashing Detail

