

NOTES

1. Eave Plate to run from steel line to steel line.
2. Sculptured Eave Trim to run from out of wall to out of wall.
3. Install Metal Inside Closure @ 2'-0" O.C. Use 6" long ~ 3/32" x 1" Roll Tape Sealant.
4. Apply continuous run of 3/16" x 7/8" Double Bead Roll Tape Sealant on top of Simple Eave Trim and over Metal Inside Closure.
5. Add 4" long ~ 7/32" x 1 3/8" Strip Tape at Minor Ribs before installing panel.
6. 3" long ~ 3/32" x 1" Roll Tape Sealant must marry into Double Bead sealant below and Seam Sealant above.

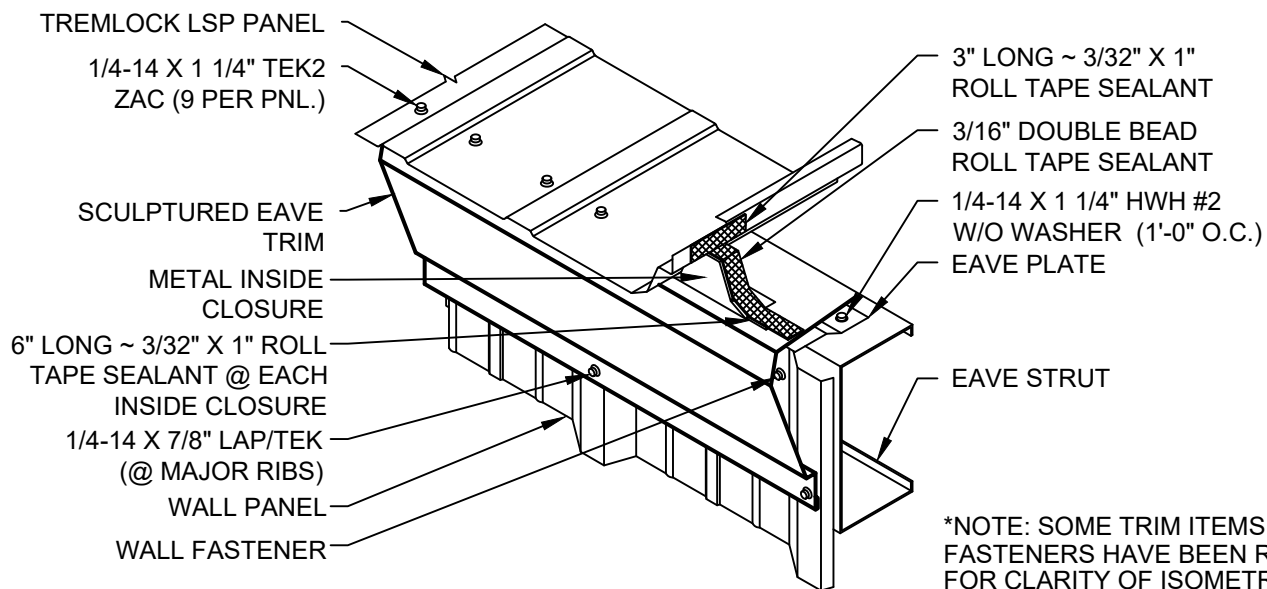

*NOTE: SOME TRIM ITEMS AND FASTENERS HAVE BEEN REMOVED FOR CLARITY OF ISOMETRIC DETAIL.