

*NOTE: MALE LEG OF PANEL MUST BE HAND FOLDED AT RAKE END FOR PROPER CONNECTION.

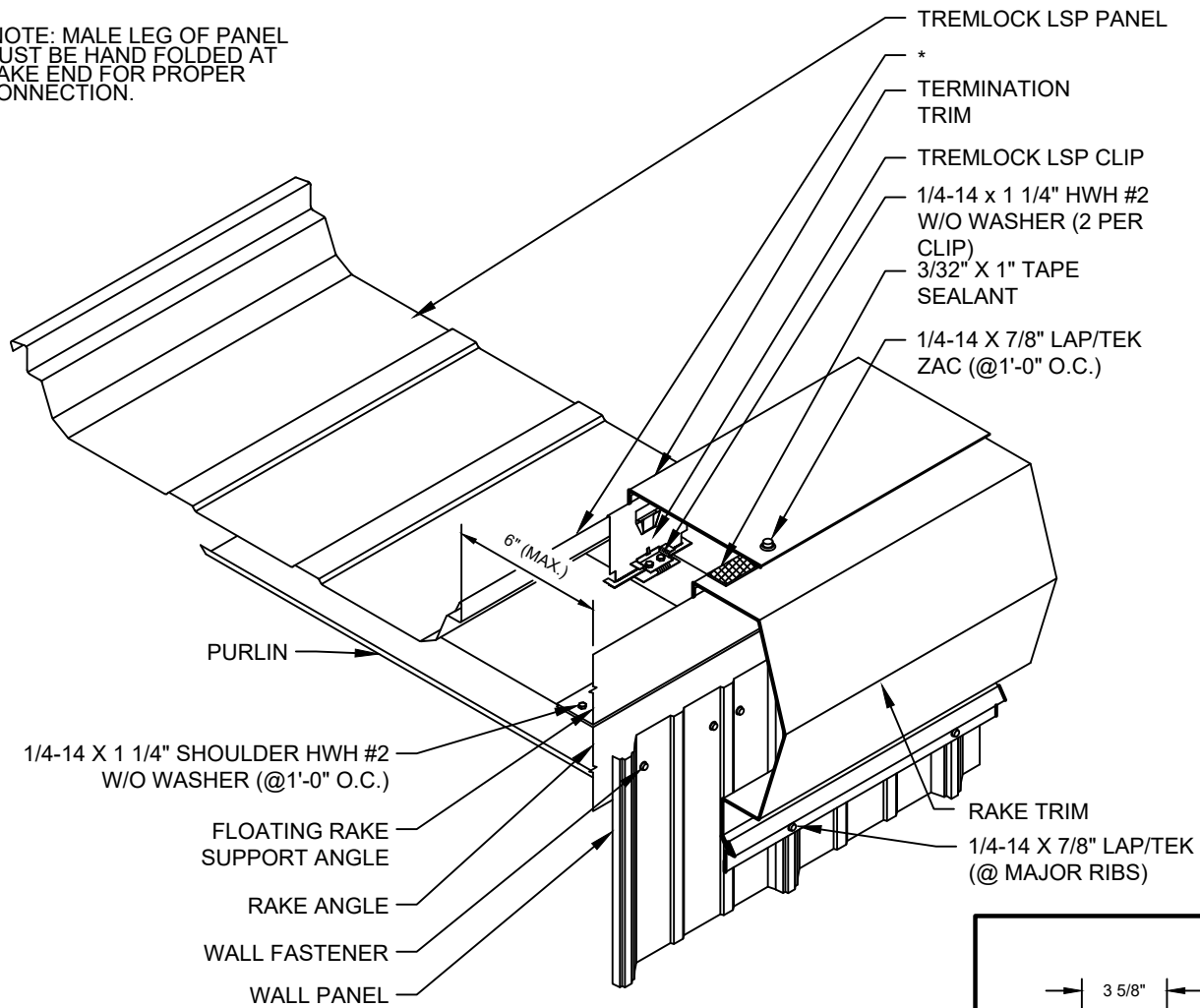

NOTE: SOME TRIM ITEMS AND FASTENERS HAVE BEEN REMOVED FOR CLARITY OF ISOMETRIC DETAIL.

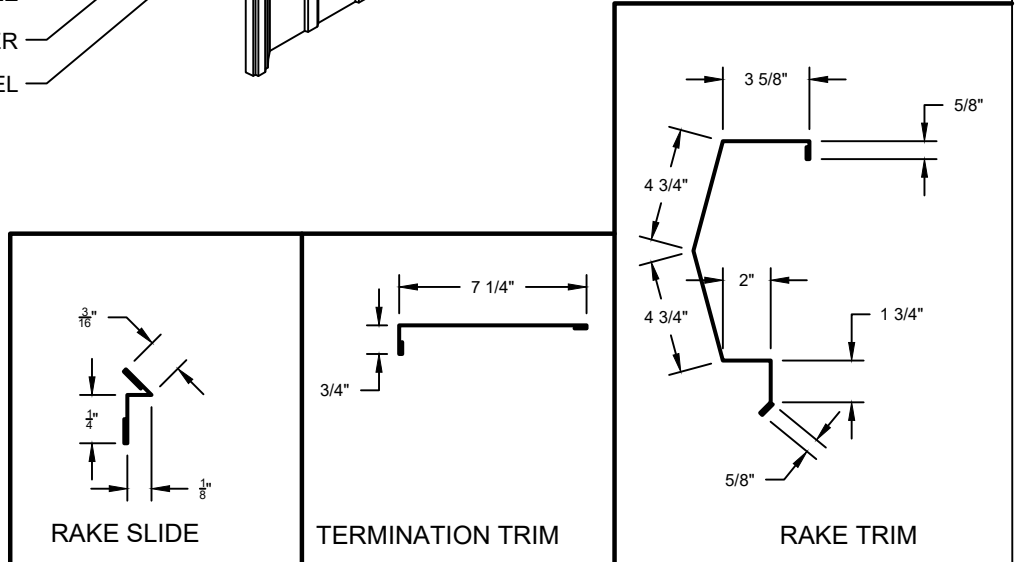

- NOTE:**
1. Rake Support Angle to be installed flush with steel line.
 2. Place roll tape on rib of roof panel and top of Rake Trim.
 3. Attach Rake Trim to support angle with 1/4-14 x 1 1/4" Tek2 Zac fasteners @1'-0" O.C.
 4. Attach Termination Trim to panel with 1/4-14 x 7/8" Lap/Tek fasteners.
 5. Attach Rake Slide to wall panels with 1/4-14 x 7/8" Lap/Tek fasteners.
 6. Apply tube sealant to trim before lapping.
 7. Pop-Rivet trim laps.



SHEET TITLE:

TREMLOCK LSP RAKE END
DETAIL (FLOATING-OFF MODULE)

SCALE:

NTS

DRAWING No.:

DWG NO. LSP-12