

**NOTES**

1. RAKE SUPPORT ANGLE TO BE INSTALLED FLUSH WITH STEEL LINE.
2. PLACE ROLL TAPE ON RIB OF ROOF PANEL.
3. ATTACH TRIM TO PANEL WITH 1/4-14 X 1 1/4" TEK2 ZAC FASTENERS @1'-0" O.C.
4. ATTACH TRIM TO WALL PANELS WITH 1/4-14 X 7/8" LAP/TEK FASTENERS.
5. APPLY TUBE SEALANT TO TRIM BEFORE LAPPING.
6. POP-RIVET TRIM LAPS.

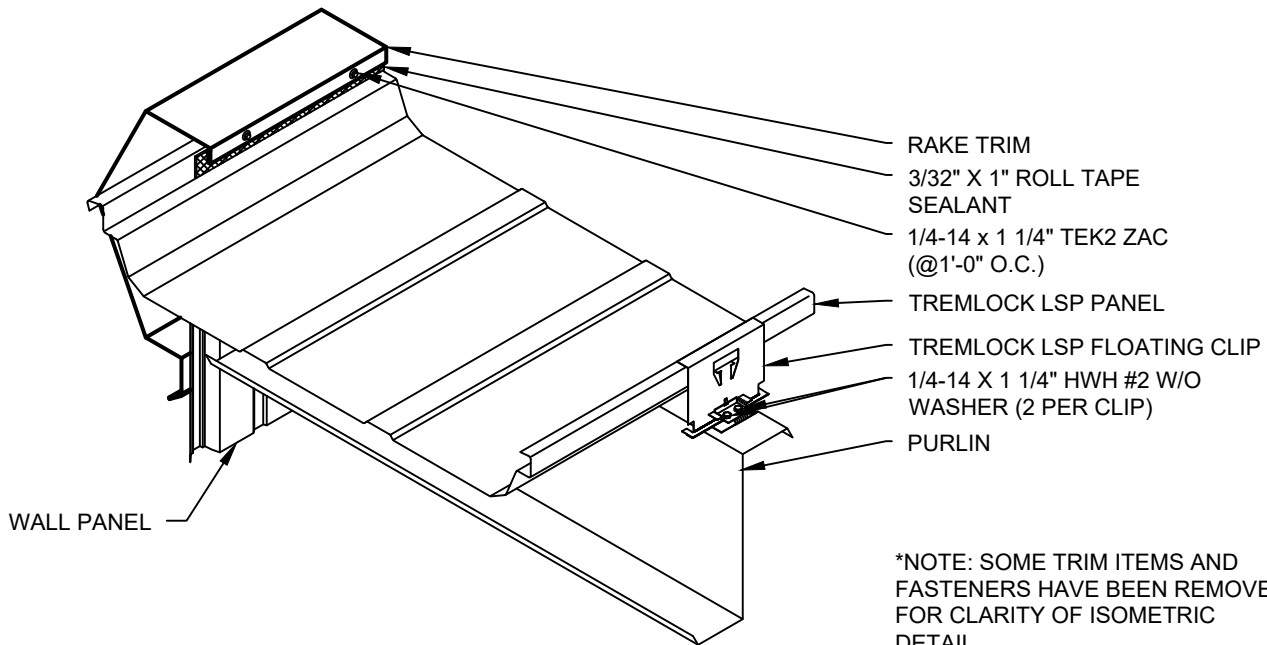

\*NOTE: SOME TRIM ITEMS AND FASTENERS HAVE BEEN REMOVED FOR CLARITY OF ISOMETRIC DETAIL.



SHEET TITLE:  
**TREMLOCK LSP RAKE START  
 DETAIL (FIXED)**

SCALE:  
 NTS  
 DRAWING No.:  
**DWG NO. LSP-14**