

**STANDARD 16GA CLIP**  
(2) FASTENER REQUIRED PER CONNECTION MIN.

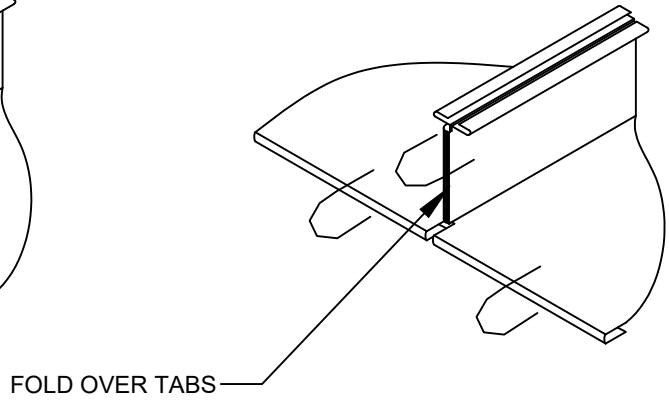

**ULTRASPAN CLIP**  
2-PIECE (24GA)  
(4) FASTENER REQUIRED PER CONNECTION (2 PER SIDE)

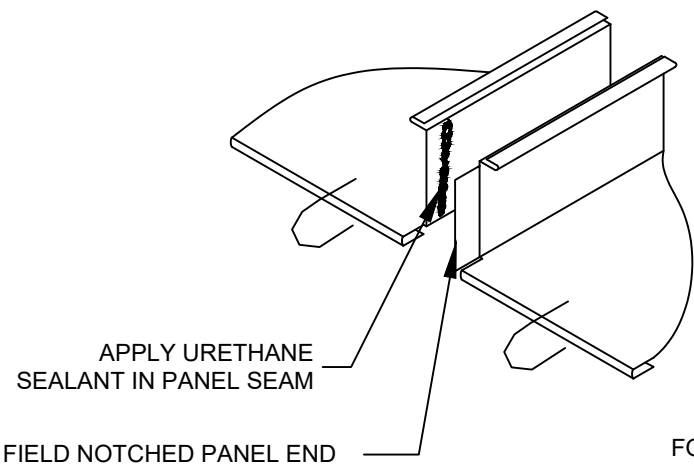

**NOTES**

1. FASTENERS SHOWN IN THIS DETAIL MAY NOT BE THE FASTENER USED FOR YOUR PROJECT. BE SURE TO USE FASTENERS SPECIFIC FOR YOUR ROOF APPLICATION. FASTENERS SHOWN ARE A REPRESENTATION OF WHAT MAY BE REQUIRED.
2. AN APPROVED HIGH TEMP SYNTHETIC UNDERLAYMENT MAY BE USED.
3. IF THE SLOPE IS LESS THAN 3/12, TREMCO INC. REQUIRES A HIGH TEMP SELF-ADHERED UNDERLAYMENT.



SHEET TITLE:  
TREMLOCK T-238 EAVE  
OVER PLYWOOD

SCALE:  
NTS  
DRAWING No.:  
DWG NO. T-238-01