

INSULATION REMOVED FOR CLARITY OF DETAIL

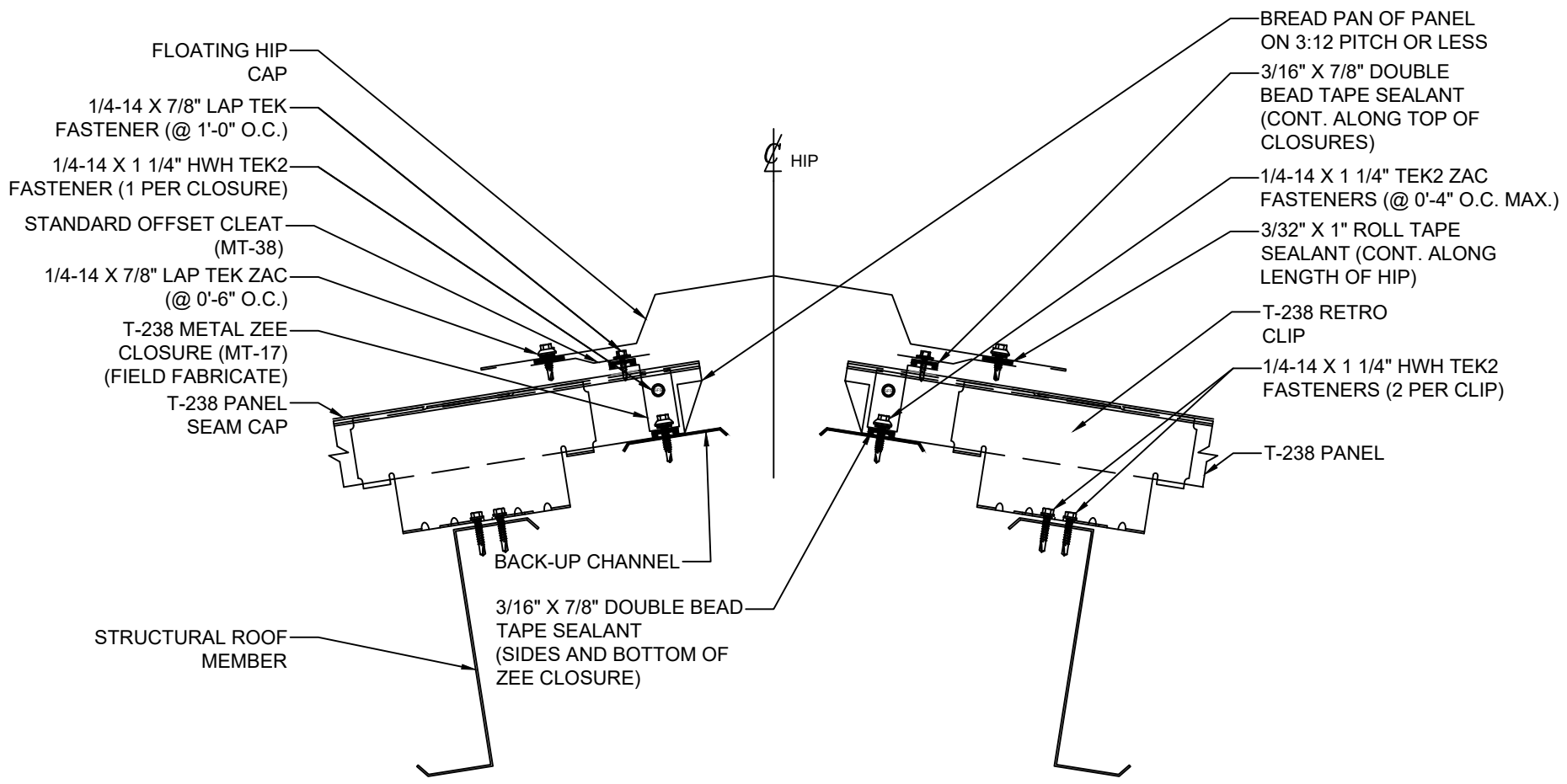

FLOATING HIP CAP

1/4-14 X 7/8" LAP TEK FASTENER (@ 1'-0" O.C.)

1/4-14 X 1 1/4" HWH TEK2 FASTENER (1 PER CLOSURE)

STANDARD OFFSET CLEAT (MT-38)

1/4-14 X 7/8" LAP TEK ZAC (@ 0'-6" O.C.)

T-238 METAL ZEE CLOSURE (MT-17) (FIELD FABRICATE)

T-238 PANEL SEAM CAP

HIP

BREAD PAN OF PANEL ON 3:12 PITCH OR LESS

3/16" X 7/8" DOUBLE BEAD TAPE SEALANT (CONT. ALONG TOP OF CLOSURES)

1/4-14 X 1 1/4" TEK2 ZAC FASTENERS (@ 0'-4" O.C. MAX.)

3/32" X 1" ROLL TAPE SEALANT (CONT. ALONG LENGTH OF HIP)

T-238 RETRO CLIP

1/4-14 X 1 1/4" HWH TEK2 FASTENERS (2 PER CLIP)

T-238 PANEL

BACK-UP CHANNEL

3/16" X 7/8" DOUBLE BEAD TAPE SEALANT (SIDES AND BOTTOM OF ZEE CLOSURE)

STRUCTURAL ROOF MEMBER



SHEET TITLE:

TREMLOCK T-238 PURLIN FLOATING HIP (RETRO CLIPS)

SCALE:

NTS

DRAWING No.:

DWG NO. T-238-59