

STEP 1.

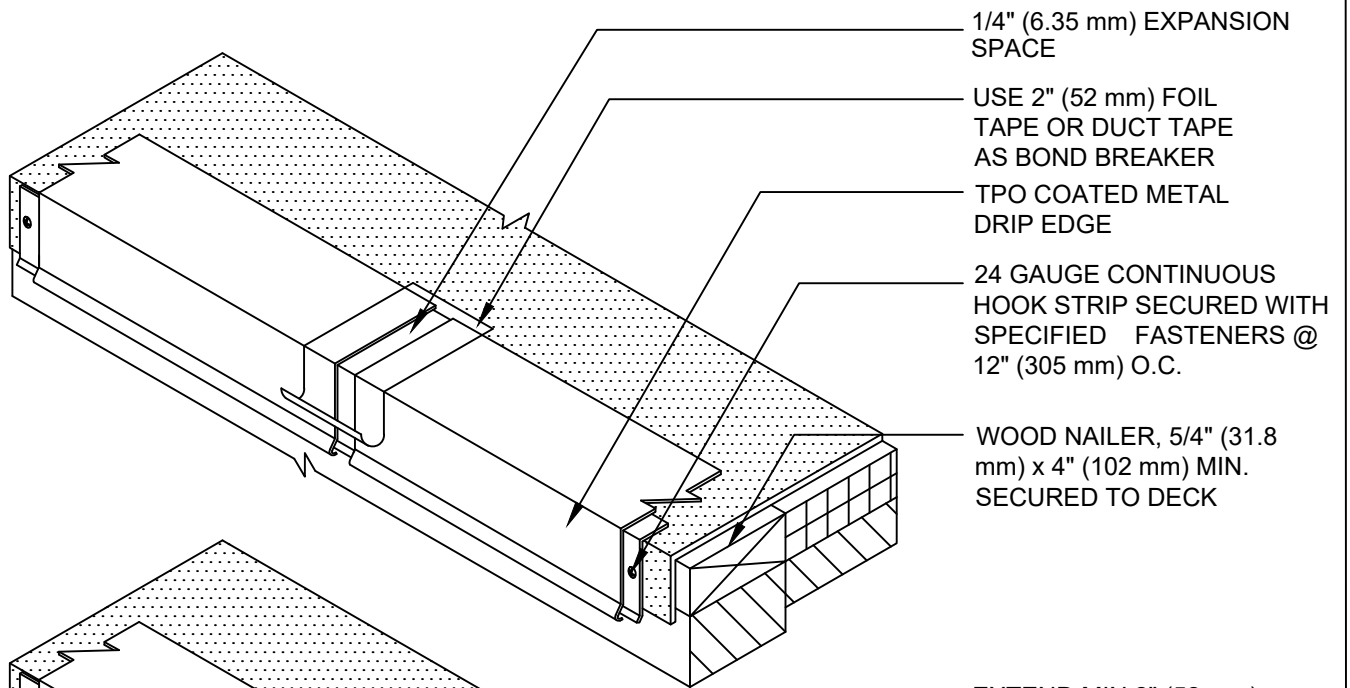

STEP 2.

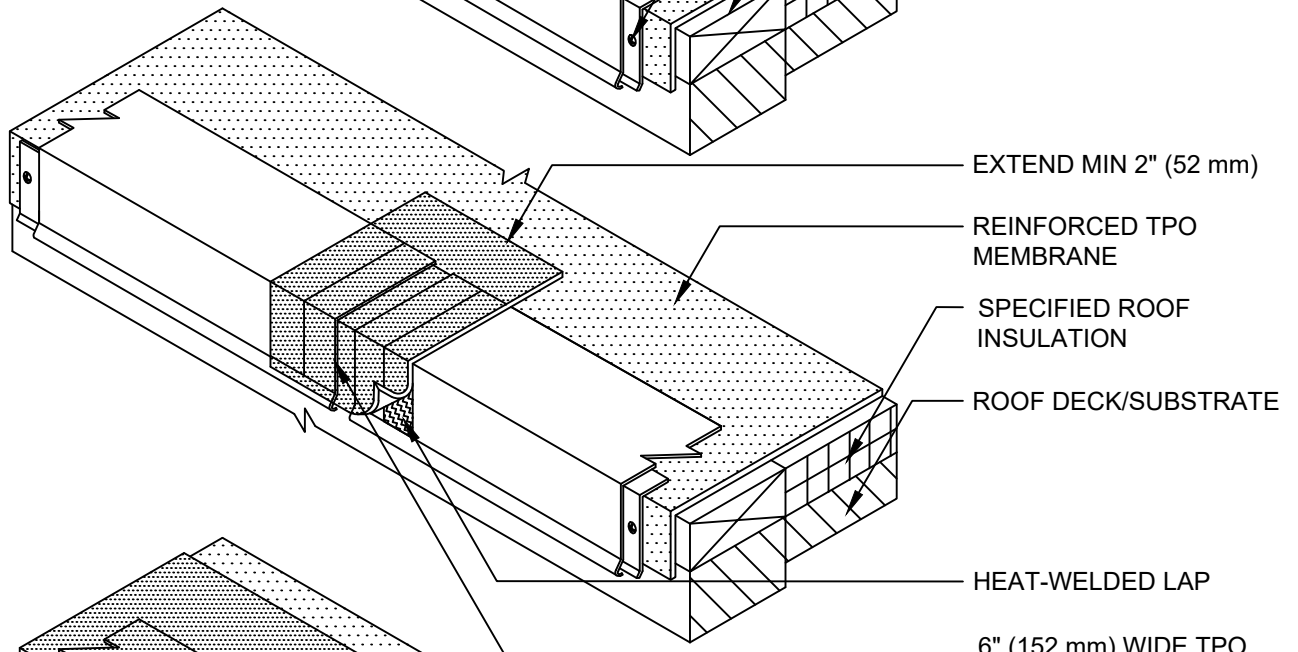

STEP 3.

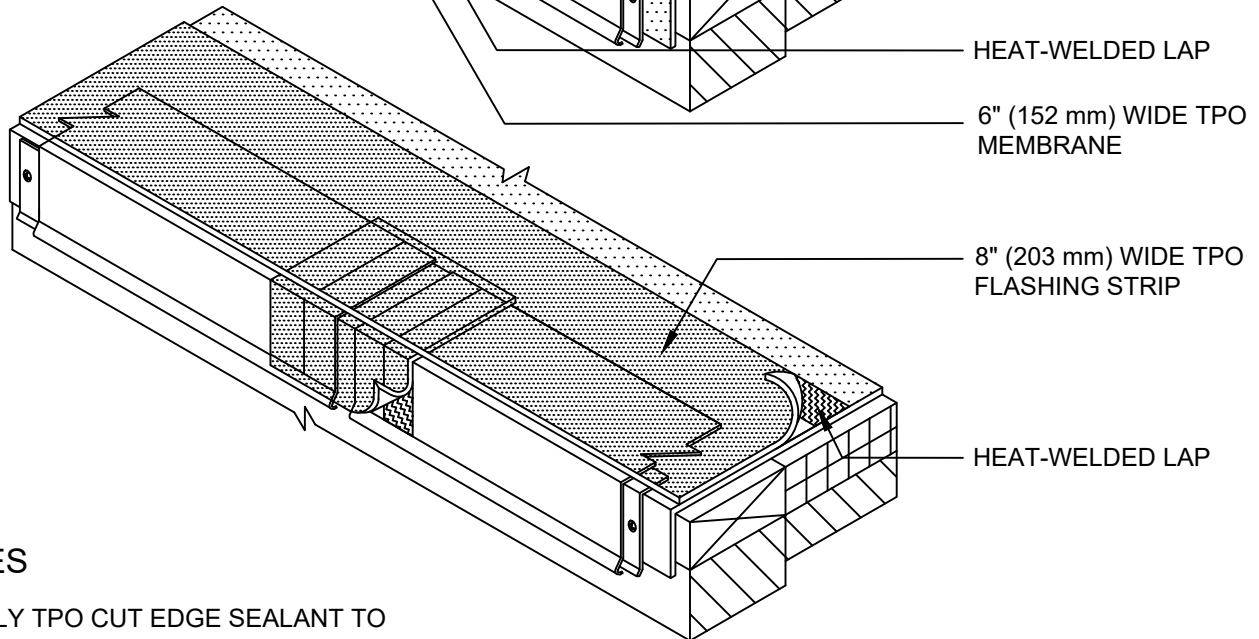

### NOTES

1. APPLY TPO CUT EDGE SEALANT TO ALL CUT REINFORCED TPO EDGES