

ALTERNATE INSTALLATION

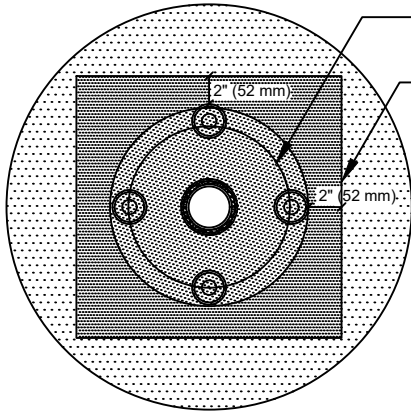

SEE NOTE #2

TPO PREMOLDED VENT BOOT

TARGET MADE FROM TPO MEMBRANE

STAINLESS STEEL CLAMP

VENT STACK

APPROVED CAULK GRADE SEALANT

TREMCO WATER BLOCK OR APPROVED CAULK GRADE SEALANT

PREMOLDED VENT BOOT

APPROVED PLATES & SCREWS 4 PER PENETRATION

HEAT-WELDED LAP

REINFORCED TPO MEMBRANE

APPROVED ROOF INSULATION

ROOF DECK/SUBSTRATE

NOTES

1. DO NOT CUT SIDE OF PREMOLDED BOOT. IT MUST BE PULLED OVER VENT PIPE.
2. IF THE PLATES AND FASTENERS INTRUDE INTO BOOT FLANGE AREA, THEN A TARGET MUST FIRST BE INSTALLED OVER PLATES AND FASTENERS BEFORE BOOT INSTALLATION.
3. FOR INSULATION THICKNESS GREATER THAN 8" (203 mm), A HARD BOARD IS REQUIRED ON MECHANICAL SYSTEMS ONLY.
4. APPLY TPO CUT EDGE SEALANT TO ALL CUT REINFORCED TPO EDGES.



SHEET TITLE:

PREMOLDED VENT BOOT
FLASHING DETAIL

SCALE:

NTS

DRAWING No.:

DWG NO. 64