



TremSafe™ Hatch Operator INSTALLATION MANUAL

IMPORTANT PRE-INSTALLATION NOTES

Please read the entire Installation Manual carefully before beginning the installation process. Also refer to the Product Warranty and Disclaimers on the final page of the manual. Remove all parts from the carton and, referring to Parts (next page), ensure that all parts are included prior to installation. If parts are missing, contact Tremco Safety Products at 803.309.9361, 7:30 a.m. to 7:30 p.m. EST, Monday – Friday.

The TremSafe™ Hatch Operator can be installed by one person, but it is more efficiently installed with two people. The estimated installation time is 1½ to 2 hours.

Because much of the TremSafe Hatch Operator is installed at various points on the roof access ladder, a climbing helmet and climbing harness or fall protection gear are required for the installer. Hard hats are also required for any additional installers working under the ladder.

The TremSafe Hatch Operator is designed for ladders that meet Occupational Safety and Health Administration (OSHA) standards, which recommend that the ladder be 18” wide and that rungs be 12” apart. The System can be installed on nonstandard ladders, but the installation process will be somewhat different and installation might take longer than anticipated for standard ladders.

The ideal height for the winch handle that operates the System is about 42” above the floor. This means that, on a standard ladder, the winch portion of the Drive Unit should be placed between the third and fourth ladder rungs. For a nonstandard ladder, the installer can adjust the Drive Unit location to the optimum height by moving the unit up or down as needed to have the top and bottom bracket locations clear of rungs (the top and bottom brackets are 5’ apart, so if one bracket is clear of interference by a rung, they both should be). The winch housing, which is part of the Drive Unit, has two available mounting positions, at least one of which should be clear of a rung and which should be used to attach the unit to the ladder. It is not necessary to use both of these winch housing mounting points.

Each TremSafe Hatch Operator unit is manufactured using dimensions provided by the buyer; therefore, the unit should fit with only minor adjustments. The standard TremSafe Hatch Operator unit, which includes the Drive Unit and the Lifting Tube, has a fully assembled height of 13’-6” (162”). In the event that the hatch is more than 15’ from the floor, the necessary Lifting Tube Extension (or Extensions) is included.

TOOLS AND MATERIALS REQUIRED FOR INSTALLATION*







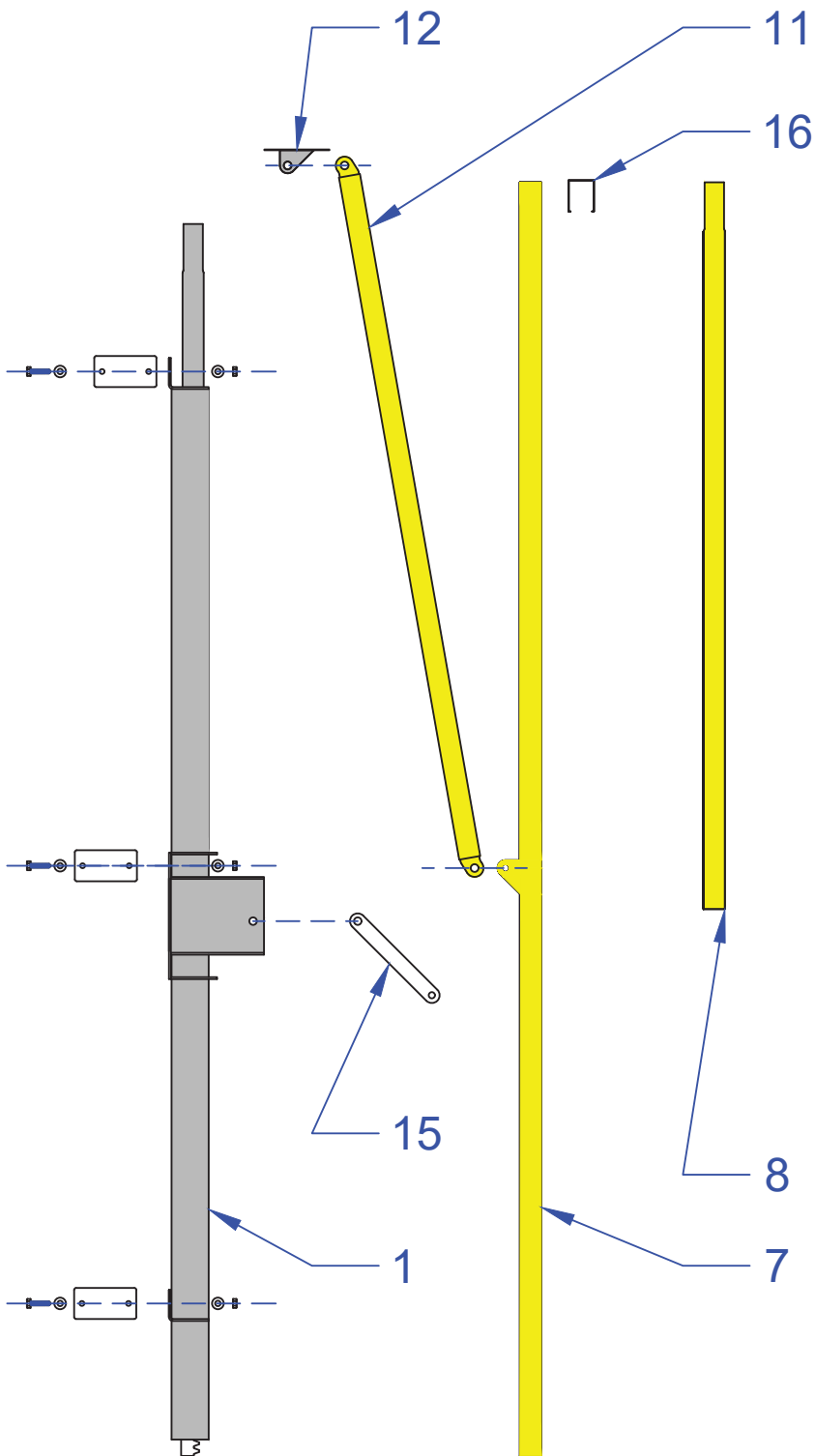

- Climbing helmet
- Climbing harness or fall protection harness
- Hard hat
- Two 6” or approximate clamps
- Two 7/16” box wrenches or sockets
- Drill with 1/8” bit
- 3/4” wrench or adjustable wrench
- Two 9/16” box wrenches or sockets
- 5/16” nut driver
- Blind rivet tool (optional)
- Tape measure
- Felt tip or other marker
- A-frame ladder (optional, if space allows and if installer would prefer to work beside rather than on the roof access ladder)

*Not included

**THIS INSTALLATION MANUAL CONTAINS IMPORTANT SAFETY INFORMATION.
READ THE ENTIRE MANUAL AND RETAIN FOR FUTURE REFERENCE.**

TremSafe Hatch Operator PARTS



		
2	3	
		
4	5	6
		
9	10	
		
13	14	
NO SCALE		

- Part 1 Drive Unit (1 included)
- Part 2 Guide Bracket (2)
- Part 3 Backing Plate (5)
- Part 4 1/4" Bolt (10)
- Part 5 1/4" Washer (20)
- Part 6 1/4" Stop Nut (10)
- Part 7 Lifting Tube (1)
- Part 8 Optional Lifting Tube Extension (1)
- Part 9 1/8" Blind Rivet (8)
- Part 10 Self-Tapping Screw (8)
- Part 11 Hatch Opener Arm (1)
- Part 12 Hatch Adaptor (1)
- Part 13 7/16" Bolt (2)
- Part 14 7/16" Stop Nut (2)
- Part 15 Handle (1)
- Part 16 Rubber Cap (1)

INSTALLATION INSTRUCTIONS

STEP 1

Determine at what height the **Drive Unit** (Part 1) will be mounted (see Important Pre-Installation Notes, Paragraph 6, for information on where the Drive Unit should be positioned).

On the side of the ladder where the unit will be mounted, clamp a **Guide Bracket** (Part 2) roughly 6" above the floor (see Illustration 1A). This Guide Bracket will help support the Drive Unit while it is being installed; after the Drive Unit is bolted on, the Guide Bracket will be removed.



ILLUSTRATION 1A

Position the Drive Unit on the Guide Bracket (see Illustration 1B) so that the Drive Unit mounting holes are against the ladder. Clamp the Drive Unit to the side of the ladder.



ILLUSTRATION 1B

INSTALLATION INSTRUCTIONS

Bolt the Drive Unit to the side of the ladder with a **Backing Plate** (Part 3) at the upper and lower Drive Unit mounting holes (A and D—see Illustration 1C), using **1/4" Bolts** (Part 4), **1/4" Washers** (Part 5), and **1/4" Stop Nuts** (Part 6). Use only the top and bottom Drive Unit mounting holes (A and D), not mounting holes B and C. Tighten bolts only until the Drive Unit stays in place; do not over-tighten bolts at this step.

Remove the Guide Bracket and the clamp that temporarily held the Drive Unit in place.

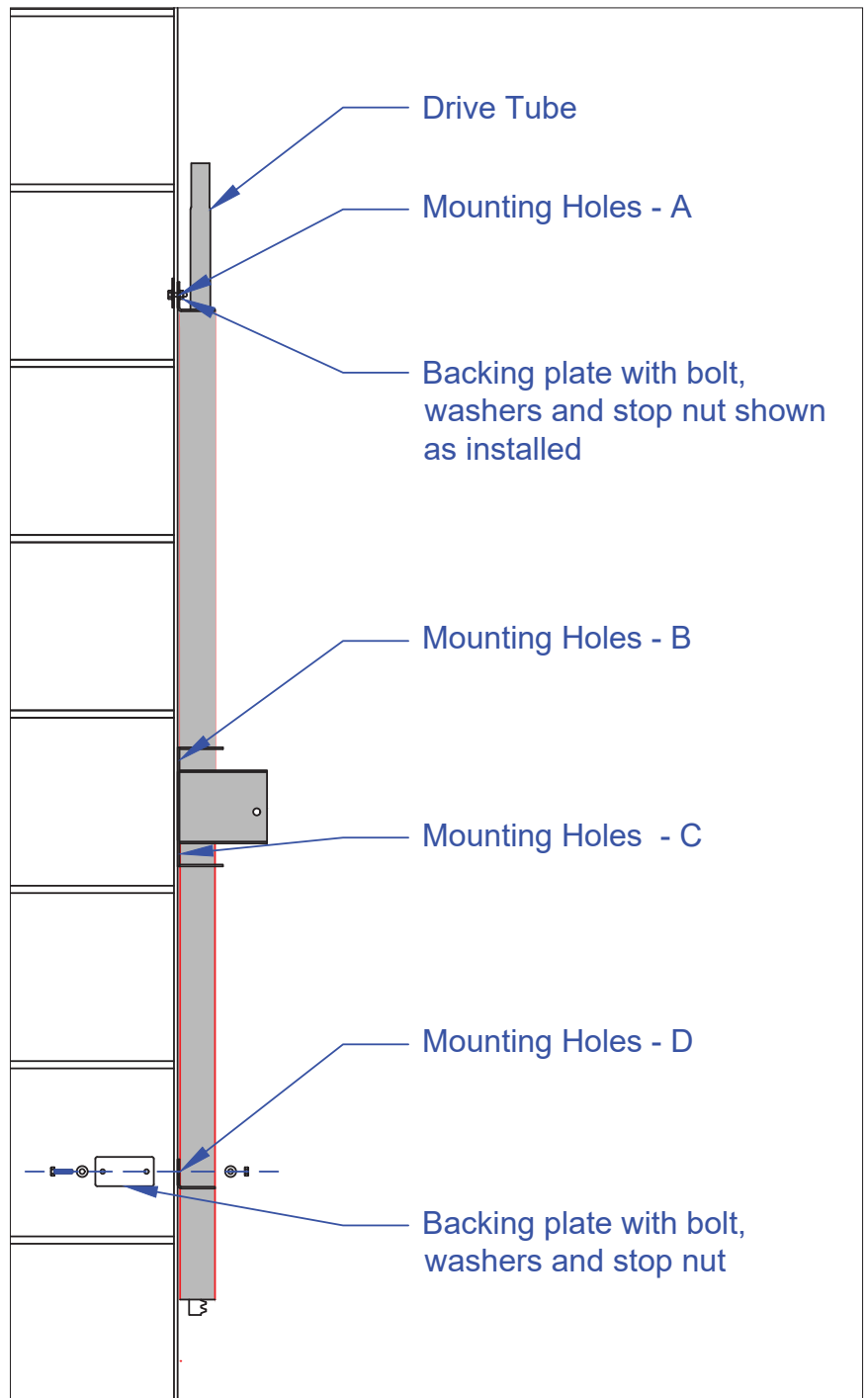

ILLUSTRATION 1C

INSTALLATION INSTRUCTIONS

STEP 2

Attach a Guide Bracket to the top of the ladder on the side where the Drive Unit is mounted, using one Backing Plate, two 1/4" Bolts, four 1/4" Washers, and two 1/4" Stop Nuts (see Illustration 2). This Guide Bracket should be as close to the top of the ladder as possible, but no closer than 4" below the underside of the closed hatch.

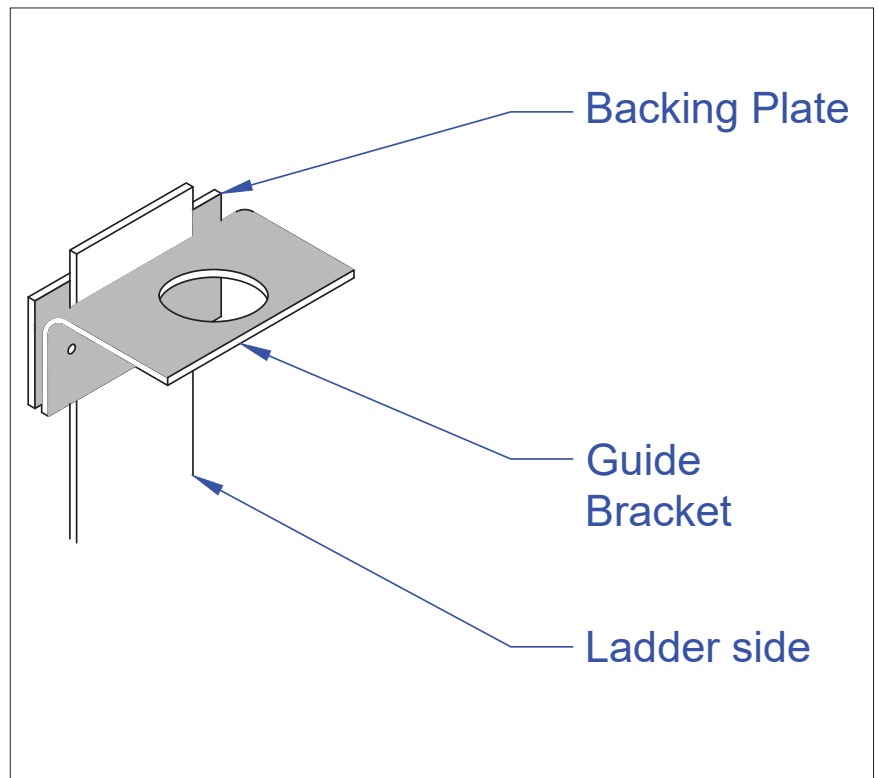

ILLUSTRATION 2

INSTALLATION INSTRUCTIONS

STEP 3

Ensure that the roof hatch is closed.

Measure from the shoulder of the Drive Tube (located at the top of the Drive Unit—see Illustration 3) to the underside of the roof hatch.

Identify the **Lifting Tube** (Part 7).

If this installation requires an **Optional Lifting Tube Extension** (Part 8), insert the Extension into the bottom of the Lifting Tube. (Note: If an Extension is required based on the dimensions provided by the buyer, that Extension will be included in the shipment; no Extensions are included if not needed.) Align the pre-drilled holes in the Lifting Tube and the Extension. Connect the two with **1/8" Blind Rivets** (Part 9) or **Self-Tapping Screws** (Part 10).

Measure the length of the Lifting Tube (or, if an Extension has been inserted, measure the entire length of the Lifting Tube and the Extension).

The Lifting Tube assembly should be 2" shorter than the distance from the shoulder of the Drive Tube to the underside of the roof hatch (see Illustration 3).

If necessary, adjust the mounting location of the Drive Unit—moving it up or down—to ensure that the Lifting Tube assembly is 2" shorter than the distance from the shoulder of the Drive Tube to the underside of the roof hatch.

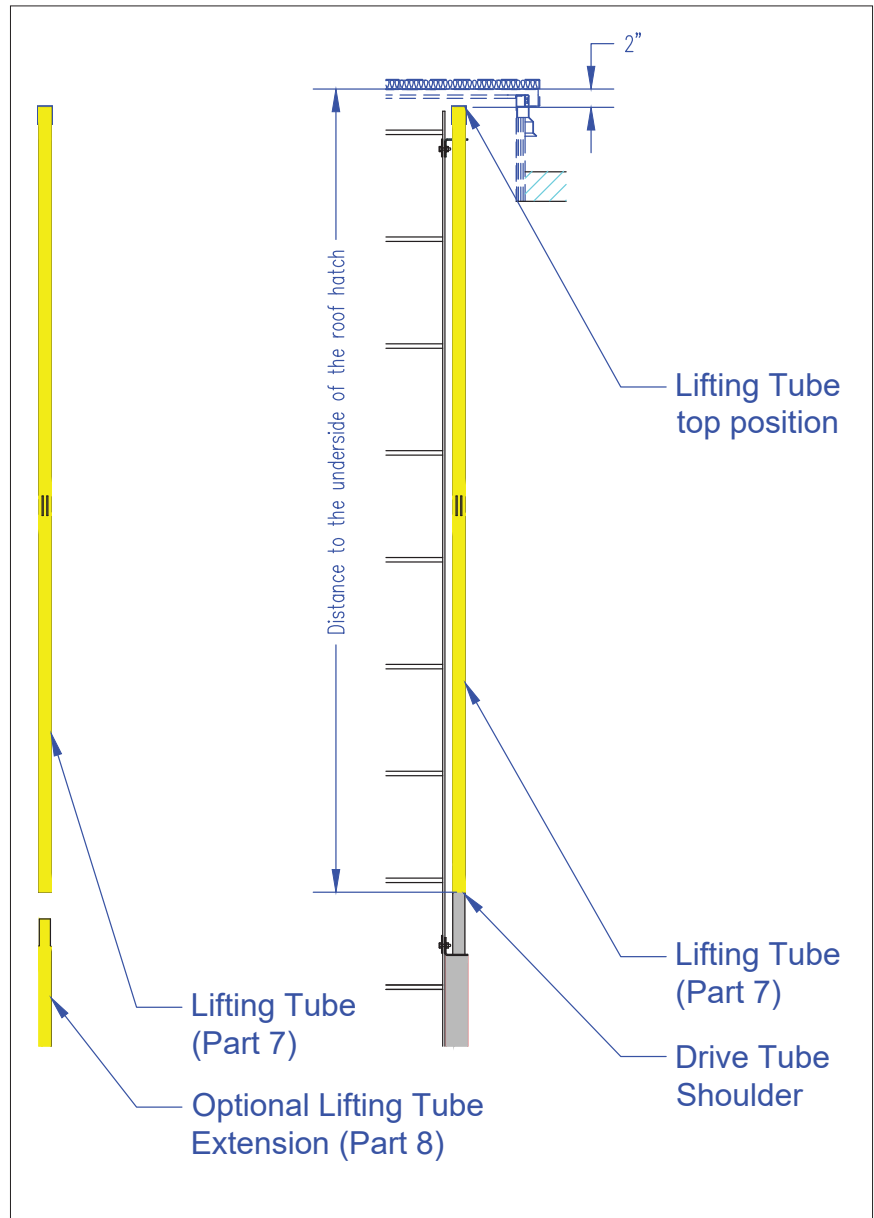

ILLUSTRATION 3

INSTALLATION INSTRUCTIONS

STEP 4

With the roof hatch open, insert the top of the Lifting Tube into the top Guide Bracket from below and slide it up until the bottom of the tube can be seated on the Drive Tube. The flanges on the Lifting Tube should be perpendicular to the ladder rungs (see Illustration 4).

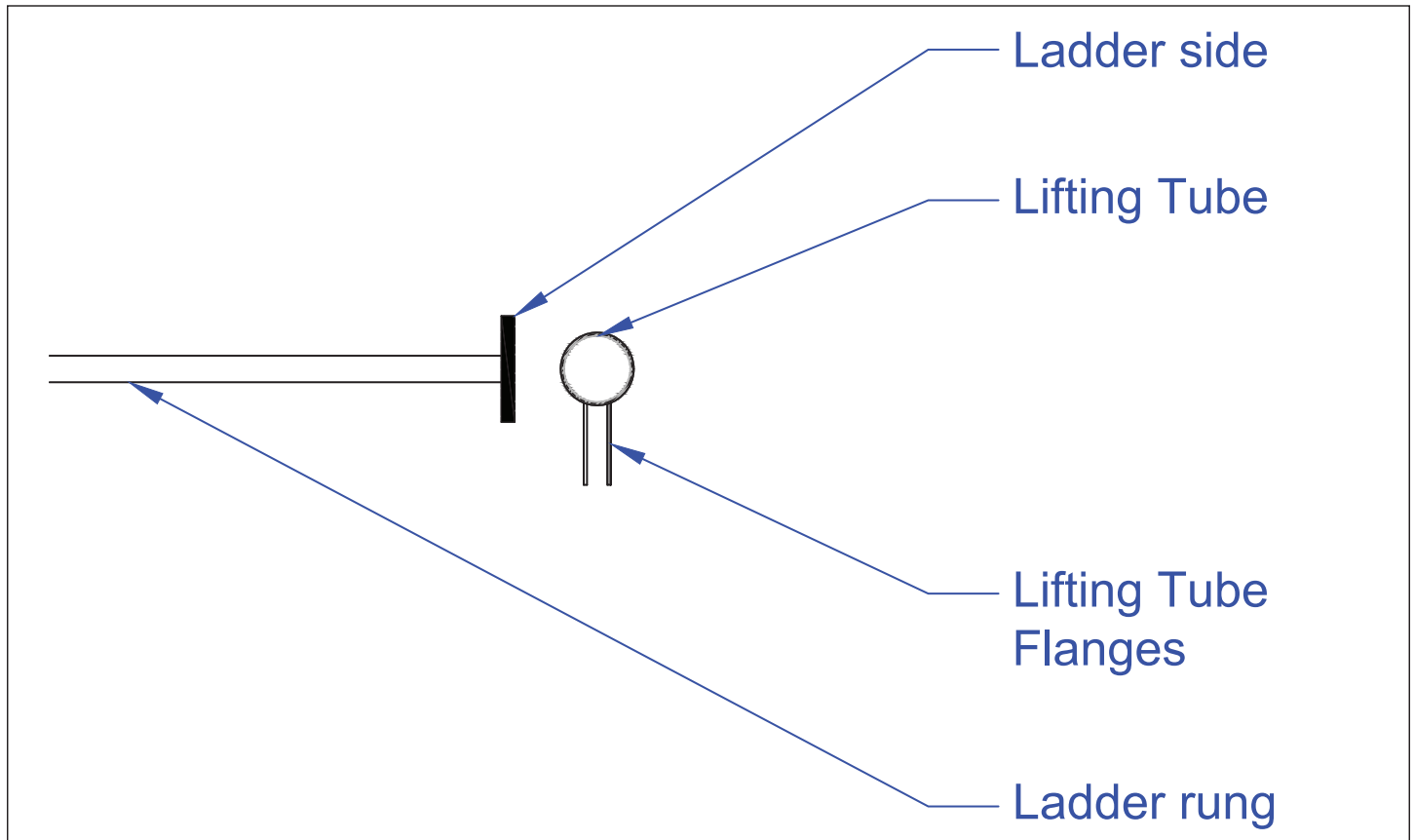

ILLUSTRATION 4

INSTALLATION INSTRUCTIONS

STEP 5

At the beginning of Step 5, the Drive Unit should be bolted to the ladder, and the Lifting Tube should be seated on the Drive Tube at the top of the Drive Unit.

Attach the **Hatch Opener Arm** (Part 11) to the **Hatch Adaptor** (Part 12), using a **7/16" Bolt** (Part 13) and **7/16" Stop Nut** (Part 14) (see Illustrations 5A and 5B).

Attach the Hatch Opener Arm to the Lifting Tube, using a 7/16" Bolt and a 7/16" Stop Nut (see Illustrations 5C and 5D).

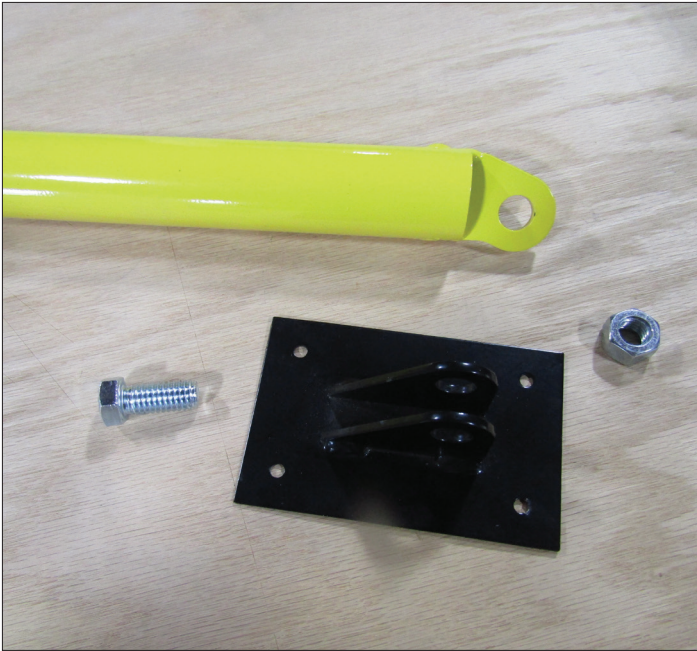

ILLUSTRATION 5A

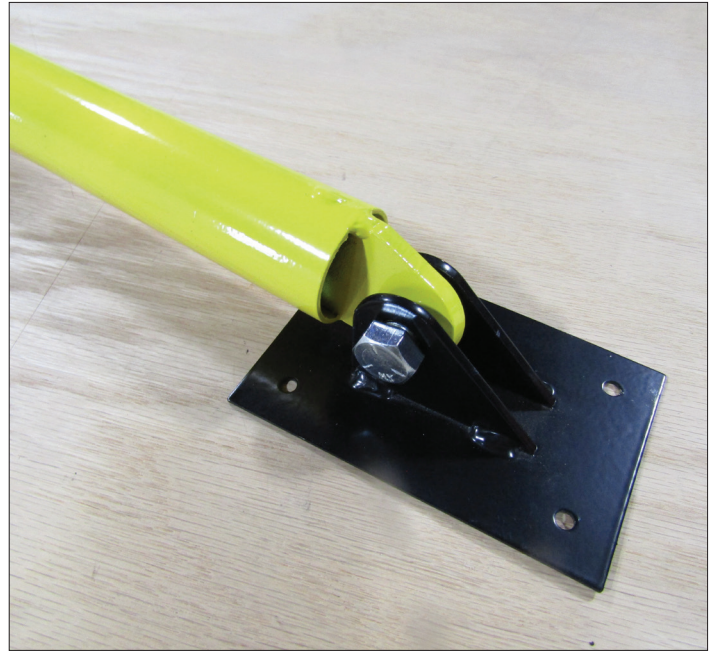

ILLUSTRATION 5B



ILLUSTRATION 5C



ILLUSTRATION 5D

INSTALLATION INSTRUCTIONS

STEP 6

Attach the **Handle** (Part 15) to the Drive Unit (see Illustration 6).



ILLUSTRATION 6

STEP 7

Close the roof hatch. Manually raise the Hatch Opener Arm until the flat side of the Hatch Adaptor is in full contact with the underside of the roof hatch. If this is possible, proceed to Step 8. If there is a small gap between the flat side of the Hatch Adaptor and the underside of the roof hatch, use the Drive Unit Handle to raise the Lifting Tube until the flat side of the Hatch Adaptor is fully against the underside of the roof hatch (see Illustration 7).

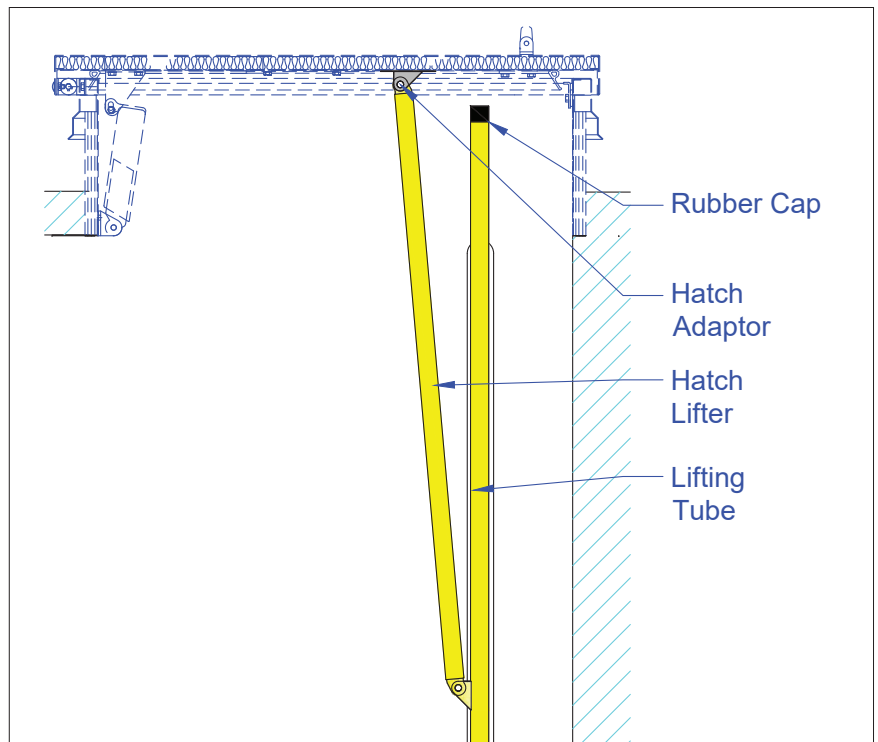

ILLUSTRATION 7

INSTALLATION INSTRUCTIONS

STEP 8

Using the pre-drilled holes in the Hatch Adaptor, attach the Hatch Adaptor to the underside of the roof hatch using Self-Tapping Screws. For ease of installation, attach the Hatch Adaptor first through pre-drilled holes 1 and 2, with the hatch closed; then, open the hatch and finish attaching the Hatch Adaptor through pre-drilled holes 3 and 4 (see Illustration 8). Place the **Rubber Cap** (Part 16) on the top of the Lifting Tube (see Illustration 7).

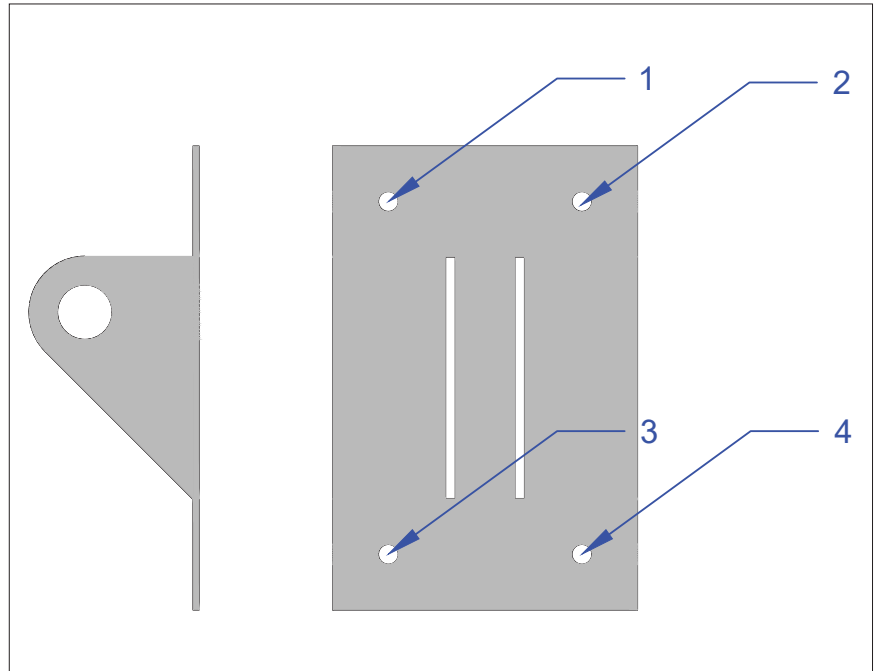

ILLUSTRATION 8

STEP 9

Using 1/8" Rivets or Self-Tapping Screws, attach the Drive Unit to the Lifting Tube.

STEP 10

Remove the factory-installed lock receiver and handle from the roof hatch. This will prevent these mechanisms from inhibiting the operation of the TremSafe Hatch Operator System.

FINAL STEP

Once the entire unit is assembled and has been tested, it is necessary to ensure that the roof hatch has a weatherproof seal. To accomplish this, completely close the roof hatch. Ensure that the TremSafe Hatch Operator System is in the locked position. Loosen Bolts A and D, at the top and bottom of the Drive Unit. Allow the Drive Unit to settle, if necessary. Then retighten Bolts A and D and install a Backing Plate at either position B or C, using 1/4" Bolts, 1/4" Washers, and 1/4" Stop Nuts.